



Compact Integrated Design

Mounted inboard at the stern, the jet draws water through an intake fixed in the hull bottom. The intake is protected by a highly developed screen which is largely self-cleaning.

The pumping unit passes through the transom and discharges water directly aft through the outlet nozzle.

The intake block aligns the jet to allow close direct drive coupling of the engine. A gearbox can also be used if necessary.

Design and manufacture are to international certifying authority standards. Corrosion resistant materials are used throughout the HJ241 jet, with further protection provided by an integral system of sacrificial anodes.

High Propulsive Efficiency

With a computer aided mixed-flow style impeller design, high propulsive efficiency is achieved at planing speeds. High resistance to cavitation is exhibited by the HJ241 jet and any number of jets can be employed without loss of propulsive efficiency.

The HJ241 waterjet is able to be direct driven by a high rpm marine diesel engine or "big block" gasoline marine engine.

Optimised Controls Package

For maximum control, steering and reverse functions of the HJ241 waterjet are separate but integrated components of the package...

Steering is by a single steerable nozzle which deflects the jet-stream to port or starboard for powerful steering effect. Steering is effected by a tiller mounted inboard on the jet with control normally being via a manual hydraulic steering system.

Reverse is achieved by lowering the jet's split duct astern deflector through the jet-stream aft of the steerable nozzle, redirecting the stream forward under the hull for powerful astern thrust.

Control of the astern deflector is by a cable operated Hydraulic Servo Reverse Control (HSRX) system – a follow-up system where the astern deflector "follows" the control lever movement.

The HSRX system incorporates a jet mounted and driven hydraulic pump, actuating cylinder and control valve, oil cooler cast into the jet intake and hydraulic piping. The HSRX system is fully factory tested before shipping.

Precision Vessel Control

The independent astern deflector provides variable propulsive thrust between full ahead and full astern.

As the steering and reverse deflectors are mounted independently, full steering effect remains available regardless of vessel speed or direction so that, with appropriate thrust vectoring alone, total vessel control is available. This includes manoeuvres such as 360 degree on-the-spot rotation and true sideways movement in multi-jet installations.

Typical Twin HJ241 Application



HamiltonJet

HJ241 Waterjet

HIGH THRUST MARINE JET PROPULSION

The Hamilton HJ241 waterjet is a compact, highly efficient marine propulsion system for use in a wide range of work and patrol boats and recreational cruisers. It is capable of accepting power inputs up to 260kW (350hp).



SCOPE OF USE

Planing Speed Craft (>25 Knots)

For planing craft, higher hull speeds achieve higher propulsive efficiency. Cruise speeds of 25 knots and higher will provide greatest efficiency (equal or better than propellers).

| Maximum Recommended Displacement (tonnes) | Single Jet | Twin Jets | Triple Jets |
|---|------------|-----------|-------------|
| | 3 - 4 | 6.5 - 9 | 10 - 14 |

Maximum Recommended Power Input / Jet – 260kW (350hp)

Semi-Planing Speed Craft (10-25 Knots)

Resistance of some hull shapes operating in this speed range can be extremely high – consult Hamilton Jet in all cases.

Maximum Recommended Power Input / Jet – 115kW (150hp)

Displacement Speed Craft (<10 Knots)

The HJ241 waterjet can be used for applications with boat speeds as low as 5 knots where shallow draught, safety and manoeuvrability are required. However, at such speeds the power input must reduce and propulsive efficiency will drop as speed declines.

| Maximum Recommended Displacement (tonnes) | Single Jet | Twin Jets | Triple Jets |
|---|------------|-----------|-------------|
| | 7.5 | 16.5 | 26 |

Maximum Recommended Power Input / Jet – 80kW (105hp)

Multiple Speed Craft

Since waterjets eliminate engine overload and appendage drag, the HJ241 jet is a simple solution for multiple speed capability. Mixed with other size waterjets or propulsion systems, applications can include low speed loiter propulsion or high speed boost function.

Note: The above information should be used as a guide only. Refer to Hamilton Jet Application Guide and Hamilton Jet HJ241 Designer's Manual for detailed advice on suitable hull shapes, optional extras available and an Application Check List for submitting vessel details to Hamilton Jet for appraisal.



World Headquarters

C.W.F Hamilton & Co Ltd
PO Box 709
Christchurch, New Zealand
Ph: +64 3 348 4179
Fax: +64 3 348 6969
E-mail: marketing@hamjet.co.nz
Web: www.hamjet.co.nz

American Office

HamiltonJet Inc
1111 NW Ballard Way
Seattle, WA 98107
United States of America
Ph: +1 206 784 8400
Fax: +1 206 783 7323
E-mail: marketing@hamiltonjet.com
Web: www.hamiltonjet.com

European Office

HamiltonJet (UK) Ltd
Unit 4A, The Birches Industrial Estate
East Grinstead, West Sussex RH19 1XZ
United Kingdom
Ph: +44 1342 313 437
Fax: +44 1342 313 438
E-mail: sales@hamjetuk.com

Plus Authorised Distributors in over 50 locations around the world

DIMENSIONS

Dimensions below are indicative only (in mm) – refer to HJ241 Designer's Manual for complete technical data.

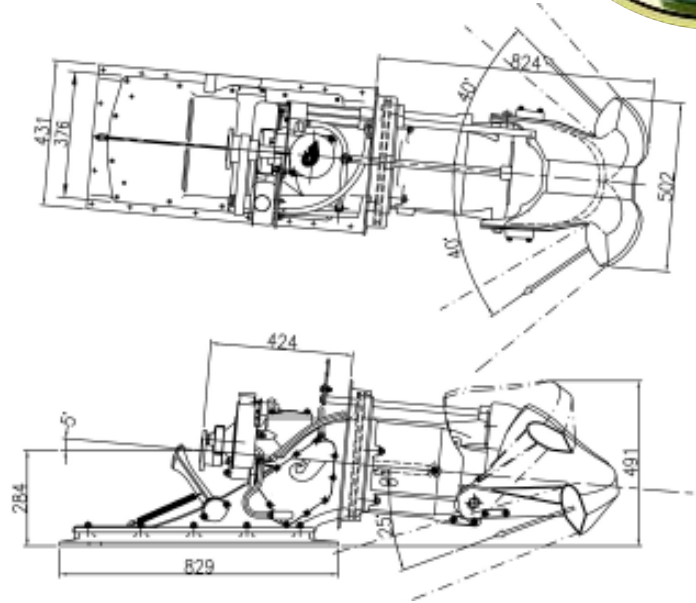

WATERJET FEATURES

- Excellent Manoeuvrability** – Throughout entire speed range
- High Efficiency** – Better than propellers at medium to high planing speeds
- Low Drag** – Significantly reduces hull resistance
- Total Safety for Marine Life & Swimmers** – No exposed propeller or rudder
- Shallow Draught** – Smooth hull bottom with no vulnerable appendages
- Low Maintenance** – Minimum downtime and simple maintenance routines
- Smooth & Quiet** – No hull vibrations or torque effect for total comfort
- Maximum Engine Life** – Impeller finely matched to engine eliminates overload
- Simplicity** – Single module replaces rudder, shaft, propeller, struts etc
- Easy to Install** – Completely packaged unit ready to bolt in

PERFORMANCE CHECK

Quote the following for a computer analysis (monohulls only)...

- Maximum laden displacement
- Waterline length
- Maximum chine beam
- Required speeds
- Deadrise angle at midships and at transom
- Proposed engine(s)
 - make/model
 - maximum intermittent rating
 - maximum continuous rating

Your Hamilton Jet Authorised Distributor is:

Due to Hamilton Jet's policy of continuous development, all specifications are subject to change without notice or obligation.